

apm6366 WiFi 802.11b/g/n Single System Module

DESCRIPTION

With a small form factor of 13×13×1.85mm (typ.), the apm6366 is a full-featured WiFi 802.11b/g/n WiFi single system module that includes support for high linear output power, IEEE 802.11i security, IEEE 802.11e QoS,. By providing SDIO (1-bit, 4-bit) host interface combined with support for Linux operation systems, the apm6366 enables rapid integration of WiFi technology into a variety of host devices. The pre-tested module eliminates the need to create custom WLAN designs, resulting in greatly reduced development risk, costs and time-to-market.

GENERAL FEATURES

- Small footprint: 13×13×1.85 mm (typ.)
- IEEE 802.11b/g/n compliant
- DSSS with DBPSK and DQPSK, CCK modulation with long and short preamble
- OFDM with BPSK, QPSK, 16QAM, and 64QAM modulation
- Complete 802.11n solution for 2.4GHz
- Complies with SDIO 1.1/2.0/3.0 for WLAN with clock rate up to 100MHz
- One transmit and one receive path (1T1R)
- 20MHz and 40MHz bandwidth transmission
- Power savings features and low power consumption for battery powered applications

- Support IEEE 802.11e QoS Enhancement (WMM)
- Support IEEE 802.11i (WPA, WPA2). Open, shared key, and pair-wise key authentication services
- RoHS compliant

APPLICATIONS

- Smartphone / PDA / PDA phone / WiFi phone / DSC / DVC with WiFi connectivity
- Printer Server / Multifunctional peripheral with WiFi connectivity

APPEARANCE

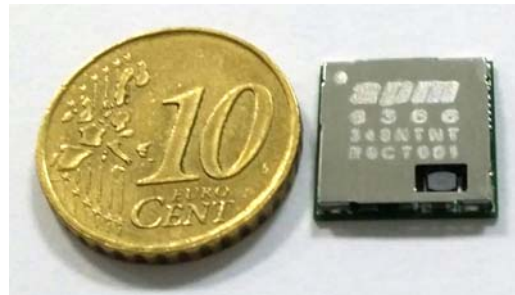

REVISION HISTORY

Date	Release	Author	Description
2013/4/22	0.1	Pol	Initial release
2013/11/14	1.0	Pol	Updated bottom ground pad size in section 2-1 and assembly guideline in section 3
2013/12/25	1.1	Pol	Updated RF specification in section 1-5-2 and current consumption in section 1-6 Updated package outline in section 2-1
2014/1/2	1.2	Pol	Updated current consumption in section 1-6 and stencil aperture in section 3-2 Updated block diagram in section 1-2

TABLE OF CONTENTS

1 HARDWARE SPECIFICATION	4
1-1 GENERAL SPECIFICATION	4
1-2 BLOCK DIAGRAM	4
1-3 PINOUT	5
1-3-1 PIN ASSIGNMENT (TOP VIEW)	5
1-3-2 PIN DESCRIPTION	5
1-4 ELECTRICAL SPECIFICATION	6
1-4-1 ABSOLUTE MAXIMUM RATING	6
1-4-2 RECOMMENDED OPERATING CONDITIONS	6
1-5 RF SPECIFICATION 802.11B/G/N	7
1-5-1 OPERATING FREQUENCY	7
1-5-2 TRANSMITTER AND RECEIVER RF SPECIFICATION	7
1-6 CURRENT CONSUMPTION 802.11B/G/N	9
2 MECHANICAL SPECIFICATION	10
2-1 PACKAGE OUTLINE	10
3 ASSEMBLY GUIDELINE	11
3-1 RECOMMENDED MOUNTING PAD DESIGN (TOP VIEW)	11
3-2 RECOMMENDATION FOR STENCIL APERTURE IN SMT PROCESS	11
3-3 BAKING CONDITION RECOMMENDATION BEFORE IR REFLOW	13
3-4 RECOMMENDATION FOR REFLOW PROFILE	13

1 Hardware Specification

1-1 General Specification

WiFi part:

Network Standard	IEEE 802.11b/g/n Compliant
Host Interface	SDIO v2.0: SDIO 1-bit, SDIO 4-bit, SDIO SPI
Frequency Band	2400 to 2472MHz (1 to 13 channels)
Data Transfer Mode	OFDM & DSSS
Modulation	64QAM (MCS0-7, 400/800ns 72.2, 65, 58.5, 57.8, 52, 43.3, 39, 28.9, 26, 21.7, 19.5, 14.4, 13, 7.2, 6.5Mbps), 64QAM (54, 48Mbps), 16QAM (36, 24Mbps), QPSK (18, 12Mbps), BPSK (9, 6Mbps); CCK (11, 5.5 Mbps), DQPSK (2 Mbps), DBPSK (1Mbps). STBC reception for MCS0-7
Access Method	Ad hoc mode, Infrastructure mode, Soft Access point (Hot spot), Wifi direct
Media Access Protocol	CSMA/ CA (Carrier Sense Multiple Access with Collision Avoidance)
Antenna	External single antenna support. The output impedance is 50Ω.

1-2 Block Diagram

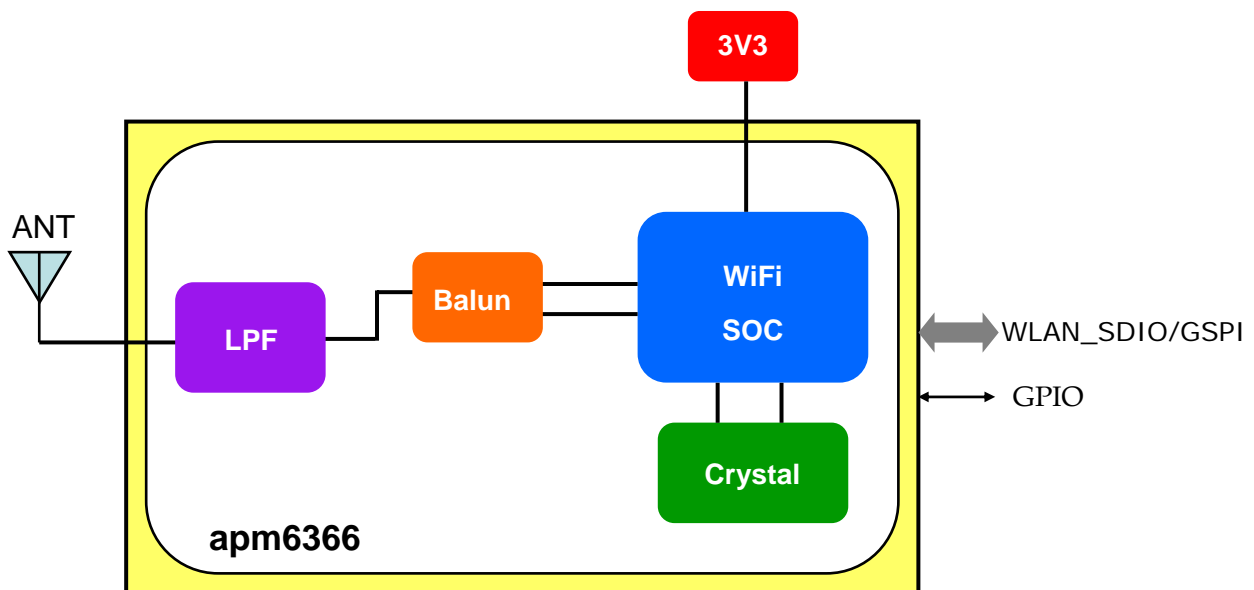

1-3 Pinout

1-3-1 Pin Assignment (Top View)

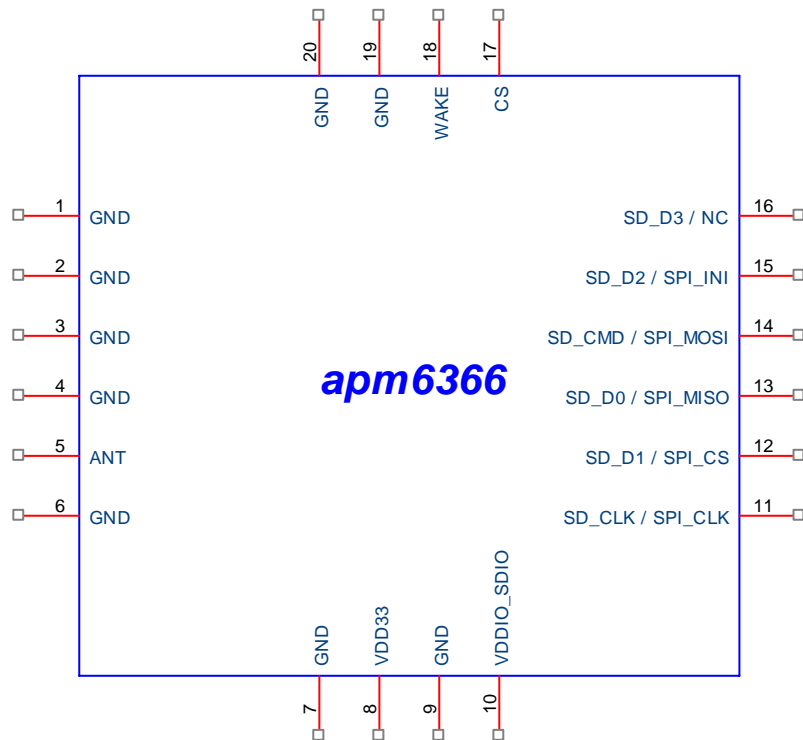

1-3-2 Pin Description

* I/O: Digital Input/Output, I: Digital Input, O: Digital Output, A: Analog, P: Power, G: GND

#	Name	I/O	Description
1	GND	G	Module ground
2	GND	G	Module ground
3	GND	G	Module ground
4	GND	G	Module ground
5	ANT	A	RF input/output
6	GND	G	Module ground
7	GND	G	Module ground
8	VDD33	P	Power supply for +3V3
9	GND	G	Module ground
10	VDDIO_SDIO	P	VDD for SDIO Pin, the power supply is same as the signal level of SDIO bus (3.3V~1.8V)
11	SD_CLK/SPI_CLK	I	SDIO Clock Input/GSPI Clock Input
12	SD_D1/SPI_CS	I/O	SDIO Data Line 1/GSPI Chip Select Bar
13	SD_D0/SPI_MISO	I/O	SDIO Data Line 0/GSPI Data Out

#	Name	I/O	Description
14	SD_CMD/SPI_MOSI	I/O	SDIO Command Input/GSPI Data Input
15	SD_D2/SPI_INI	I/O	SDIO Data Line 2/GSPI Interrupt
16	SD_D3	I/O	SDIO Data Line 3
17	CS	I	This pin can external shutdown apm6366 without extra power switch.
18	WAKE	O	This pin is for WiFi function to wakeup host when remote wake function is enabled. The polarity can be defined by customer.
19	GND	G	Module ground
20	GND	G	Module ground

All the big pads on the bottom of the module should be tied to ground.

1-4 Electrical Specification

1-4-1 Absolute Maximum Rating

Symbol	Description	Min.	Max.	Units
T _{ST}	Storage temperature	-30	+85	°C
VDD33	Main supply voltage	-0.3	+3.6	V
VDDIO_SDIO	Supply voltage for SDIO	-0.3	+3.6	V

1-4-2 Recommended Operating Conditions

Symbol	Description	Min.	Typ.	Max.	Units
T _{OP}	Operating temperature	-20	+25	+70	°C
VDD33	Main supply voltage	+3.0	+3.3	+3.6	V
VDDIO_SDIO	Supply voltage for SDIO	+1.7	+3.3	+3.6	V

1-5 RF Specification 802.11b/g/n

1-5-1 Operating frequency

Features	Description
Frequency band	2.400 GHz - 2.497 GHz
Number of channels	14 channels
Modulation	DSSS, OFDM, DBPSK, DQPSK, CCK, 16-QAM, 64-QAM
Supported rates	1, 2, 5.5, 11, 6, 9, 12, 24, 36, 48, 54, 65Mbps, 72.2Mbps, 135Mbps, 150Mbps

1-5-2 Transmitter and Receiver RF Specification

Conditions: VDD33=VDDIO_SDIO=+3.3V, T_{OP}=+25°C

Parameter	Test conditions	Units	Min.	Typ.	Max.
802.11b Transmit					
Operating frequency range		-	Ch 1	-	Ch 13
Transmit output power	1/2/5.5/11Mbps	dBm	+15.5	+17	-
Center frequency tolerance		ppm	-	+2	-
ACPR: 1 st side lobe power	Pout=+17.0dBm, 1/2/5.5/11Mbps	dBc	-	-42	-
ACPR: 2 nd side lobe power	Pout=+17.0dBm, 1/2/5.5/11Mbps	dBc	-	-59	-
Transmit EVM	11Mbps, Channel 1~13	%	-	8	35
Transmit ramp-up time	10% ~ 90%	μs	-	0.2	2
Transmit ramp-down time	90% ~ 10%	μs	-	0.4	2
802.11b Receive					
Receive minimum input level sensitivity	11Mbps CCK, FER<8% at PSDU length of 1024 bytes	dBm	-	-86	-84
Receive maximum input level capability	11Mbps CCK, FER<8% at PSDU length of 1024 bytes	dBm	-20	+0	-
802.11g Transmit					
Operating frequency range		-	Ch 1	-	Ch 13
Transmit output power	54Mbps OFDM	dBm	+13.5	+15	-
Center frequency tolerance	54Mbps OFDM	ppm	-	+2	-
Symbol clock freq. tolerance	54Mbps OFDM	ppm	-	+4	-
Transmit EVM	54Mbps OFDM, Channel 1~13	dB	-	-27	-25

Parameter	Test conditions	Units	Min.	Typ.	Max.
Transmit ramp-up time	10% ~ 90%	μs	-	0.2	2
Transmit ramp-down time	90% ~ 10%	μs	-	0.4	2
802.11g Receive					
Receive minimum input level sensitivity	54Mbps OFDM, FER<10% at PSDU length of 1024 bytes	dBm	-	-74	-72
Receive maximum input level capability	54Mbps OFDM, FER<10% at PSDU length of 1024 bytes	dBm	-20	-12	-
802.11n 20MHz Transmit					
Operating frequency range		-	Ch 1	-	Ch 13
Transmit output power	MCS7	dBm	+11.5	+13	-
Transmit modulation accuracy	MCS7	dB	-	-30	-28
Symbol clock frequency tolerance	MSC7	ppm	-	+5	-
Transmit center frequency tolerance	MCS7	ppm	-	+2	-
Spectrum Mask	$f < fc-30, fc+30 < f$	dBr	-	-55	-
	$fc-30 < f < fc-20, fc+20 < f < fc+30$	dBr	-	-41	-
	$fc-20 < f < fc-11, fc+11 < f < fc+20$	dBr	-	-28	-
	$fc-11 < f < fc-9, fc+9 < f < fc+11$	dBr	-	-18	-
802.11n 20MHz Receive					
Receive minimum input level sensitivity	MCS7 (FER<10% at PSDU length of 1024 bytes)	dBm	-	-70	-68
Receive maximum input level capability	MSC7 (FER<10% at PSDU length of 1024 bytes)	dBm	-20	-10	-
802.11n 40MHz Transmit					
Operating frequency range		-	Ch 1	-	Ch 13
Transmit output power	MCS7	dBm	+11.5	+13	-
Transmit modulation accuracy	MCS7	dB	-	-30	-28
Symbol clock frequency tolerance	MSC7	ppm	-	+5	-
Transmit center frequency tolerance	MCS7	ppm	-	+2	-
Spectrum Mask	$f < fc-30, fc+30 < f$	dBr	-	-55	-
	$fc-30 < f < fc-20, fc+20 < f < fc+30$	dBr	-	-41	-

Parameter	Test conditions	Units	Min.	Typ.	Max.
	fc-20 <f <fc-11, fc+11 <f <fc+20	dBr	-	-28	-
	fc-11 <f <fc-9, fc+9 <f <fc+11	dBr	-	-18	-
802.11n 40MHz Receive					
Receive minimum input level sensitivity	MCS7 (FER<10% at PSDU length of 1024 bytes)	dBm	-	-68	-66
Receive maximum input level capability	MSC7 (FER<10% at PSDU length of 1024 bytes)	dBm	-20	-10	-

1-6 Current Consumption 802.11b/g/n

Mode	Current Consumption (mA)
Non-associated idle	0.024
Associated idle	2.9
Tx n mode 40MHz	97
Rx n mode 40MHz	86
Tx n mode 20MHz	91
Rx n mode 20MHz	74
Tx g mode	91
Rx g mode	86
Tx b mode	103
Rx b mode	92

2 Mechanical Specification

Dimension	13×13×2.0 mm (max. height)
Pinout	20
Weight	0.666g
Antenna	External antenna support (Pin 5)

2-1 Package Outline

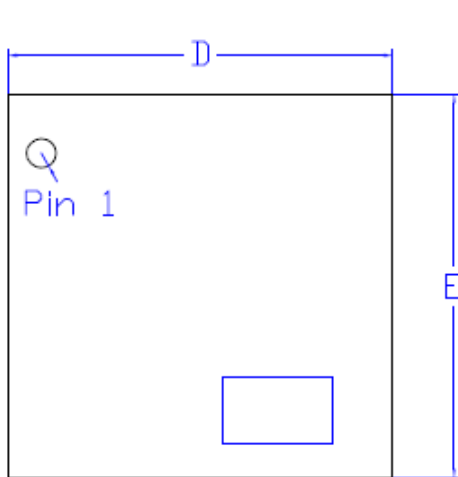

<TOP VIEW>

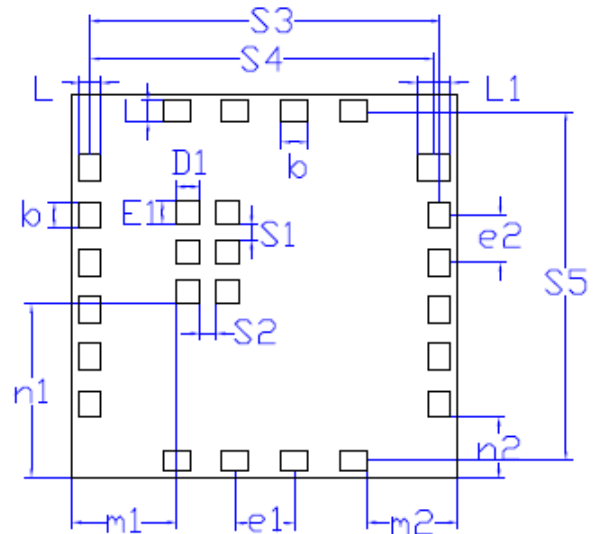

<BOTTOM VIEW>

Unit:mm

Symbol	Min	Nor	Max
D	12.9	13.0	13.1
E	12.9	13.0	13.1
A	-	1.85	2.00
A1	-	0.6	0.7
m1	3.4	3.5	3.6
n1	5.8	5.9	6.0
m2	2.95	3.05	3.15
n2	1.95	2.05	2.15
e1	-	2.0	-
e2	-	1.6	-

Symbol	Min	Nor	Max
D1	0.7	0.8	0.9
E1	0.7	0.8	0.9
L	0.62	0.72	0.82
L1	1.02	1.12	1.22
b	0.8	0.90	1.0
S1	0.45	0.55	0.65
S2	0.45	0.55	0.65
S3	11.72	11.82	11.92
S4	11.52	11.62	11.72
S5	11.72	11.82	11.92

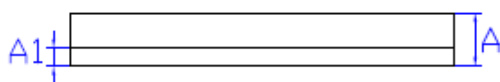

<SIDE VIEW>

3 Assembly Guideline

3-1 Recommended Mounting Pad Design (Top View)

The following figure illustrates the recommended mounting pad design for apm6366.

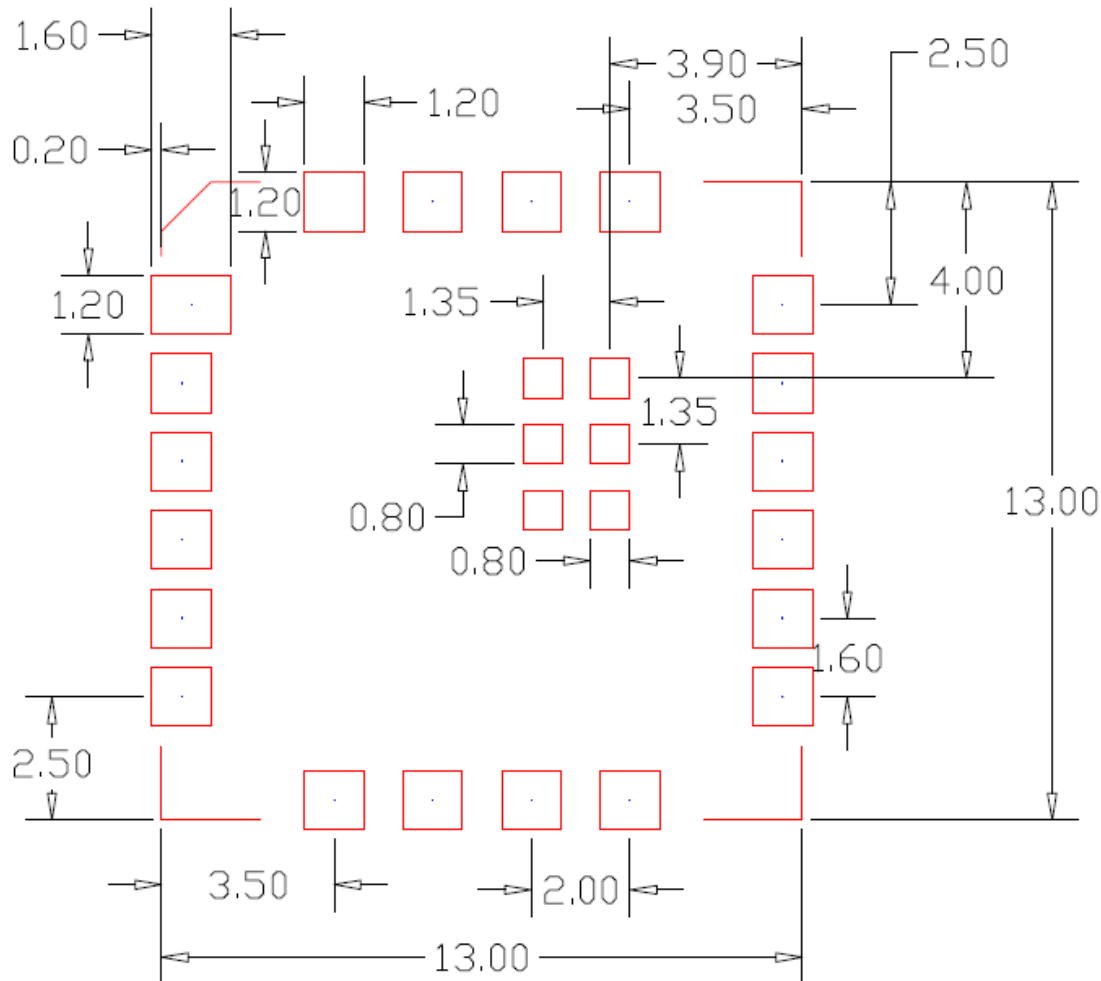

TOP VIEW(mm)

3-2 Recommendation for Stencil Aperture in SMT Process

Please follow general QFN stencil design guideline. Some rules of thumb are highlighted below.

- The LGA pads should NOT be flooded over with copper, they should be connected into the plane with a track width of approx 50% of the pad width, this will mean more heat will be available at the joint. Track lengths should obviously be minimized, we would generally use about 0.3mm on external layers.
- The thickness of the solder paste stencil has implications on solder joint quality as well, we do not have the knowledge on what stencil should be specified.

- Ensure they are using a good appropriate flux, and the correct reflow profile for unleaded (basically +20C above leaded) which is also uniform in nature.

Violating the basic rules might cause problems. For example, if the stencil apertures of the internal ground planes are improperly big, they would hold more solders in SMT process and may cause the module peripheral pads un-contacted to the main board. To improve this situation, apmcomm suggests the stencil opening shown as follows.

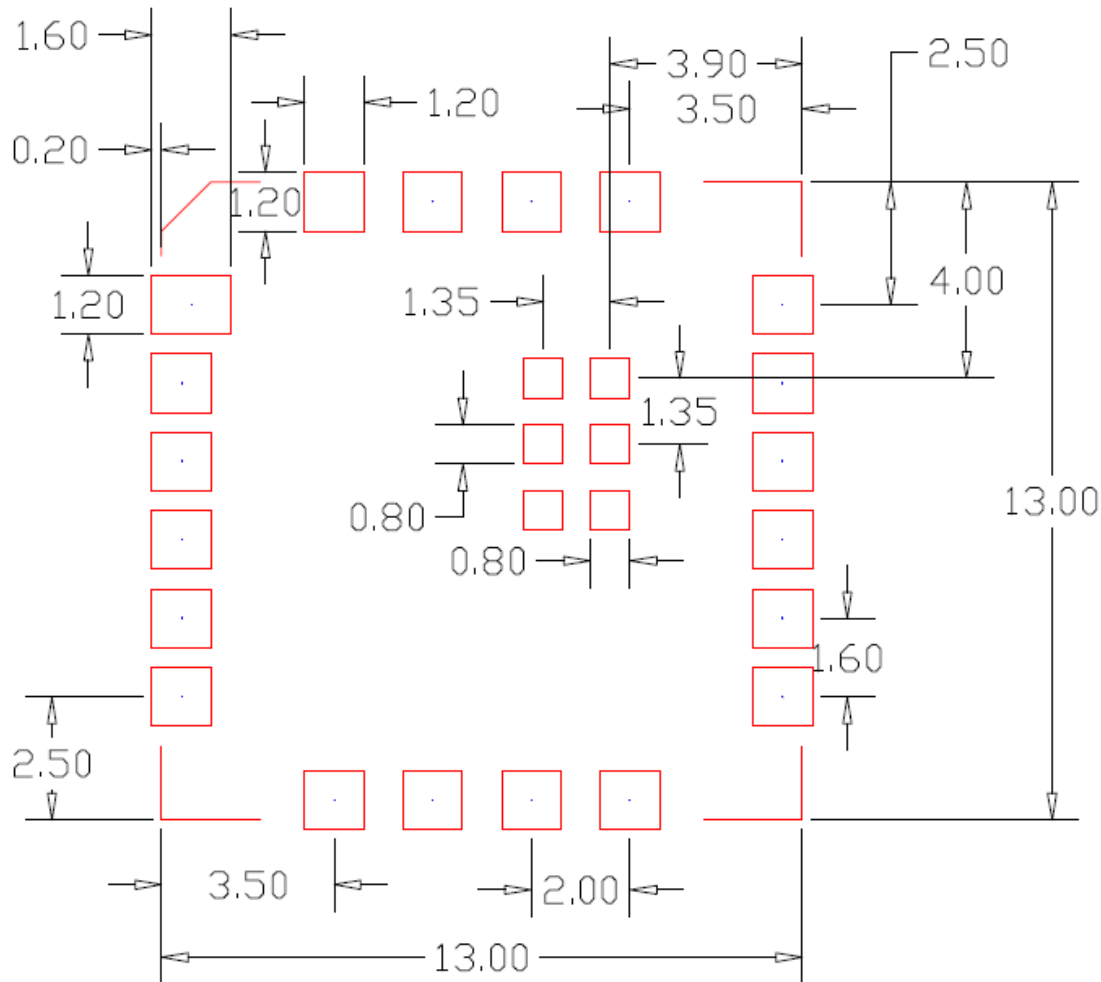

Stencil Aperture (Top View)

3-3 Baking condition recommendation before IR reflow

Baking condition for apm6366 module:

- I: 125°C/4 hrs baking is necessary for apm6366 module before SMT process. After baking treatment the modules can be stored in the environment under 30°C and 60% RH for 168 hrs. If the storage time is over 168 hrs, the modules need to be re-baked using the same condition again.
- II: In the event that the sealed bag is damaged on receipt of the modules, the baking condition should be changed to 125°C/8 hrs.

3-4 Recommendation for Reflow Profile

Maximum reflow temperature is 250°C.

Preheat ramp-up rate	125°C to 180°C 1 to 3°C /sec.
Peak temperature	250°C max.
Temperature maintained above 217°C	30 ~ 90 sec.
Cooling ramp-down rate	<2°C/sec.
Maximum number of reflow cycles	≤3

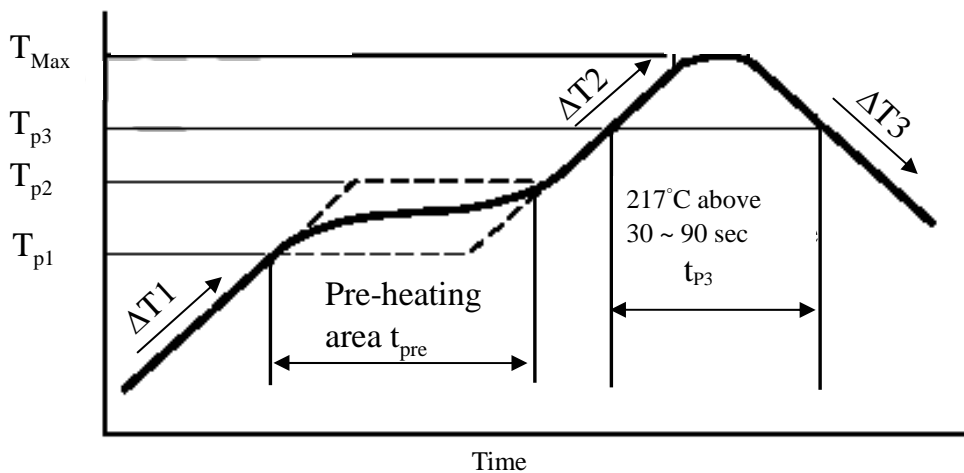

Heating/Cooling Speed			Pre-Heating		Heating	
$\Delta T1$	$\Delta T2$	$\Delta T3$	$T_{p1}-T_{p2}$	t_{pre}	T_{Max}	t_{p3}
1 to 3°C /sec.	1 to 3°C /sec.	< 2°C /sec.	125 ~ 180°C	30 ~ 90 sec.	250°C max.	30 ~ 90 sec.